

User's and Service Guide

Agilent Technologies 85038A/F/M 7-16 Calibration Kits



Agilent Part Number: 85038-90010

Printed in USA

Print Date: July 2002

Supersedes: August 2000

© Copyright 1999, 2000, 2002 Agilent Technologies, Inc. All rights reserved.

Documentation Warranty

THE MATERIAL CONTAINED IN THIS DOCUMENT IS PROVIDED "AS IS," AND IS SUBJECT TO BEING CHANGED, WITHOUT NOTICE, IN FUTURE EDITIONS. FURTHER, TO THE MAXIMUM EXTENT PERMITTED BY APPLICABLE LAW, AGILENT DISCLAIMS ALL WARRANTIES, EITHER EXPRESS OR IMPLIED WITH REGARD TO THIS MANUAL AND ANY INFORMATION CONTAINED HEREIN, INCLUDING BUT NOT LIMITED TO THE IMPLIED WARRANTIES OF MERCHANTABILITY AND FITNESS FOR A PARTICULAR PURPOSE. AGILENT SHALL NOT BE LIABLE FOR ERRORS OR FOR INCIDENTAL OR CONSEQUENTIAL DAMAGES IN CONNECTION WITH THE FURNISHING, USE, OR PERFORMANCE OF THIS DOCUMENT OR ANY INFORMATION CONTAINED HEREIN. SHOULD AGILENT AND THE USER HAVE A SEPARATE WRITTEN AGREEMENT WITH WARRANTY TERMS COVERING THE MATERIAL IN THIS DOCUMENT THAT CONFLICT WITH THESE TERMS, THE WARRANTY TERMS IN THE SEPARATE AGREEMENT WILL CONTROL.

Assistance

Product maintenance agreements and other customer assistance agreements are available for Agilent products.

For any assistance, contact Agilent Technologies. Refer to [Table 5-1 on page 5-3](#) for contact information.

Contents

1. General Information	
Calibration Kit Overview	1-2
Kit Contents	1-2
Calibration Definitions	1-2
Installation of the Calibration Definitions	1-3
Equipment Required but Not Supplied	1-3
Incoming Inspection	1-3
Serial Numbers	1-4
Recording the Device Serial Numbers	1-4
Clarifying the Sex of a Connector	1-5
Preventive Maintenance	1-5
2. Specifications	
Environmental Requirements	2-2
Temperature—What to Watch Out For	2-2
Mechanical Characteristics	2-3
Pin Depth	2-3
Electrical Specifications	2-4
Certification	2-4
Connector Standards	2-4
3. Use, Maintenance, and Care of the Devices	
Electrostatic Discharge	3-2
Visual Inspection	3-3
Look for Obvious Defects and Damage First	3-3
What Causes Connector Wear?	3-3
Inspect the Mating Plane Surfaces	3-3
Inspect Female Connectors	3-4
Cleaning Connectors	3-4
Connections	3-5
How to Make a Connection	3-5
Preliminary Connection	3-5
Final Connection Using a Torque Wrench	3-6
How to Separate a Connection	3-8
Handling and Storage	3-8
4. Performance Verification	
Introduction	4-2
How Agilent Verifies the Devices in Your Kit	4-2
Recertification	4-3
How Often to Recertify	4-3
Where to Send a Kit for Recertification	4-3
5. Troubleshooting	
Troubleshooting Process	5-2
Returning a Kit or Device to Agilent	5-3
Contacting Agilent	5-3

Contents

- 6. Replaceable Parts**
 - Introduction 6-2

- A. Standard Definitions**
 - Version Changes A-2
 - Standard Class Assignments A-2
 - Blank Form A-3
 - Nominal Standard Definitions A-4
 - Setting the System Impedance A-4
 - Blank Forms A-7

1 General Information

Calibration Kit Overview

The Agilent 85038 7-16 calibration kits are used to calibrate Agilent network analyzers up to 7.5 GHz for measurements of components with 7-16 connectors.

Kit Contents

The 85038A calibration kit includes the following:

- a male connector set (open, short, load)
- a female connector set (open, short, load)
- a data disk that contains the calibration definitions of the devices in the kit for 8510 systems, and the 872x and 875x series
- a data disk that contains the calibration definitions of the devices in the kit for the 871x and PNA series

The 85038F calibration kit includes the following:

- a female connector set (open, short, load)
- a female-to-female adapter
- a data disk that contains the calibration definitions of the devices in the kit for 8510 systems, and the 872x and 875x series
- a data disk that contains the calibration definitions of the devices in the kit for the 871x and PNA series

The 85038M calibration kit includes the following:

- a male connector set (open, short, load)
- a male-to-male adapter
- a data disk that contains the calibration definitions of the devices in the kit for 8510 systems, and the 872x and 875x series
- a data disk that contains the calibration definitions of the devices in the kit for the 871x and PNA series

Refer to [Figure 6-1](#) and [Table 6-1](#) for a complete list of kit contents and part numbers.

Calibration Definitions

The calibration kit must be selected and the calibration definitions for the devices in the kit installed in the network analyzer prior to performing a calibration. Refer to your network analyzer user's guide for instructions on selecting the calibration kit and performing a calibration.

The calibration definitions can be:

- resident within the analyzer
- loaded from the provided disk
- entered from the front panel

Installation of the Calibration Definitions

The calibration definitions for the kit may be permanently installed in the internal memory or hard disk of the network analyzer.

If the calibration definitions for the kit are not permanently installed in the network analyzer, they must be manually entered. Refer to your network analyzer user's guide for instructions.

Equipment Required but Not Supplied

Connector cleaning supplies and various electrostatic discharge (ESD) protection devices are not supplied with the calibration kit but are required to ensure successful operation of the kit. Refer to [Table 6-2 on page 6-4](#) for ordering information.

Incoming Inspection

Verify that the shipment is complete by referring to [Table 6-1 on page 6-3](#).

Check for damage. The foam-lined storage case provides protection during shipping. Verify that this case and its contents are not damaged.

If the case or any device appears damaged, or if the shipment is incomplete, contact Agilent Technologies. For contact information, see [Table 5-1 on page 5-3](#). Agilent will arrange for repair or replacement of incomplete or damaged shipments without waiting for a settlement from the transportation company.

When you send the kit or device to Agilent, include a service tag (found near the end of this manual) with the following information:

- your company name and address
- the name of a technical contact person within your company, and the person's complete phone number
- the model number and serial number of the kit
- the part number and serial number of the device
- the type of service required
- a *detailed* description of the problem

Serial Numbers

A serial number is attached to this calibration kit. The first four digits followed by a letter comprise the serial number prefix; the last five digits are the suffix, unique to each calibration kit.

Recording the Device Serial Numbers

In addition to the kit serial number, the devices in the kit are individually serialized (serial numbers are labeled onto the body of each device). Record these serial numbers in [Table 1-1](#). Recording the serial numbers will prevent confusing the devices in this kit with similar devices from other kits.

Table 1-1 Serial Number Record for the 85038A/F/M

Device	Serial Number
Calibration kit	_____
Open (m)	_____
Open (f)	_____
Short (m)	_____
Short (f)	_____
Load (m)	_____
Load (f)	_____
Adapters (7-16)	_____
Male to male	_____
Female to female	_____

Clarifying the Sex of a Connector

In this manual, calibration devices and adapters are referred to in terms of their connector interface. For example, a male open has a male connector.

However, during a measurement calibration, the network analyzer softkey menus label a calibration device with reference to the sex of the analyzer's test port connector—not the calibration device connector. For example, the label `SHORT(F)` on the analyzer's display refers to the short that is to be connected to the female test port. This will be a male short from the calibration kit.

Preventive Maintenance

The best techniques for maintaining the integrity of the devices in your kit include:

- routine visual inspection
- cleaning
- proper connection techniques

All of these are described in [Chapter 3](#), “Use, Maintenance, and Care of the Devices.”

Failure to detect and remove dirt or metallic particles on a mating plane surface can degrade repeatability and accuracy and can damage any connector mated to it. Improper connections, resulting from pin depth values being out of limit (see [Table 2-2 on page 2-3](#)) or from bad connection techniques, can also damage these devices.

2 Specifications

Environmental Requirements

Table 2-1 Environmental Requirements

Parameter	Limits
Operating temperature ^a	+20 °C to +26 °C (+68 °F to +79 °F)
Error-corrected temperature range ^b	±1 °C of measurement calibration temperature
Storage temperature	0 °C to +55 °C (–32 °F to +131 °F)
Altitude	
Operation	< 4,600 meters (≈15,000 feet)
Storage	< 15,300 meters (≈50,000 feet)
Humidity	90% for 24 hours

- a. The temperature range over which the calibration standards maintain conformance to their specifications.
- b. The allowable network analyzer ambient temperature drift during measurement calibration and during measurements when the network analyzer error correction is turned on. Also, the range over which the network analyzer maintains its specified performance while correction is turned on.

Temperature—What to Watch Out For

Changes in temperature can affect electrical characteristics. Therefore, the operating temperature is a critical factor in performance. During a measurement calibration, the temperature of the calibration devices must be stable and within the range shown in [Table 2-1](#).

IMPORTANT Avoid unnecessary handling of the devices during calibration because your fingers are a heat source.

Mechanical Characteristics

Mechanical characteristics such as pin depth are *not* performance specifications. They are, however, important supplemental characteristics related to electrical performance.

Pin Depth

Pin depth is the distance the center conductor mating plane differs from being flush with the outer conductor mating plane. See [Figure 2-1](#). Typical pin depth values for the devices in the kits are listed in [Table 2-2](#).

The pin depth of a connector can be in one of two states: either protruding or recessed.

Protrusion is the condition in which the center conductor extends beyond the outer conductor mating plane.

Recession is the condition in which the center conductor is set back from the outer conductor mating plane.

Figure 2-1 Connector Pin Depth

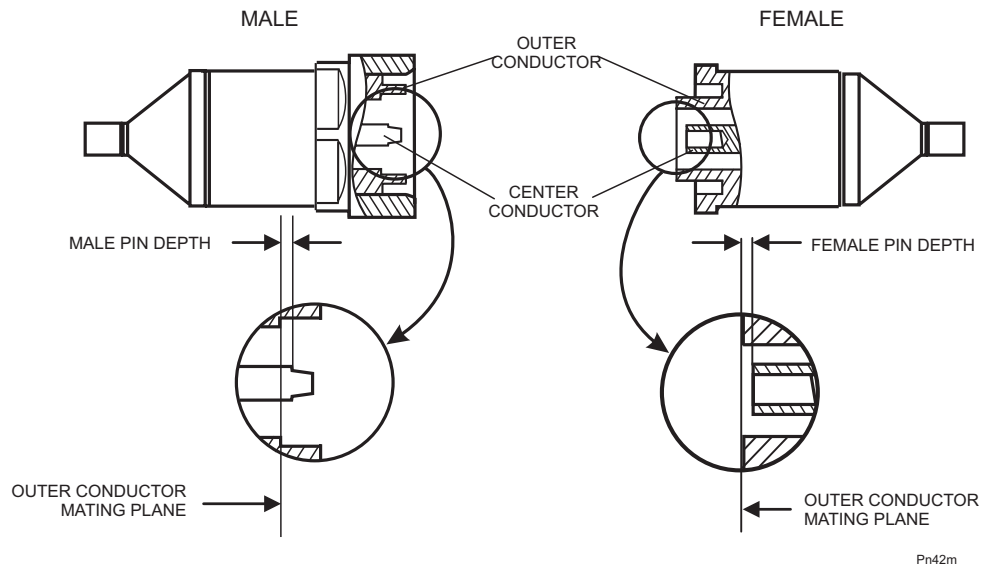

Table 2-2 Mechanical Characteristics

Dimension	Typical Value
Inside diameter of outer conductor	16.060 ±0.008 mm
Outside diameter of center conductor	6.975 ±0.005 mm
Pin depth, male devices	1.732 to 1.770 mm
Pin depth, female devices	1.770 to 1.808 mm

Electrical Specifications

The electrical specifications in [Table 2-3](#) apply to the devices in your calibration kit when connected with an Agilent precision interface.

Table 2-3 Electrical Specifications for 85038A/F/M Devices

Device	Specification	Frequency (GHz)
Loads (male and female)	Return loss ≥ 40 dB	dc to ≤ 4
	Return loss ≥ 36 dB	> 4 to ≤ 7.5
Opens ^a (male and female)	$\pm 1^\circ$ deviation from nominal phase	dc to ≤ 4
	$\pm 1.25^\circ$ deviation from nominal phase	> 4 to ≤ 7.5
Shorts ^a (male and female)	$\pm 0.6^\circ$ deviation from nominal phase	dc to ≤ 4
	$\pm 0.85^\circ$ deviation from nominal phase	> 4 to ≤ 7.5
Adapters ^b	Return loss ≥ 38 dB	dc to ≤ 7.5

a. The specifications for the opens and shorts are given as allowed deviation from the nominal model as defined in the standard definitions (see [Table A-5 on page A-5](#) and [Table A-6 on page A-6](#)).

b. Applies only to 85038F/M kits.

Certification

Agilent Technologies certifies that this product met its published specifications at the time of shipment from the factory. Agilent further certifies that its calibration measurements are traceable to the United States National Institute of Standards and Technology (NIST) to the extent allowed by the institute's calibration facility, and to the calibration facilities of other International Standards Organization members. See "[How Agilent Verifies the Devices in Your Kit,](#)" on [page 4-2](#) for more information.

Connector Standards

The 7-16 connectors in these calibration kits conform to or exceed the requirements for:

- IEC 169-4 reference grade
- DIN 47223
- EN 122190 grade 0 (European standard)
- BSEN 122190 (British standard)

3 Use, Maintenance, and Care of the Devices

Electrostatic Discharge

Protection against ESD (electrostatic discharge) is essential while connecting, inspecting, or cleaning connectors attached to a static-sensitive circuit (such as those found in test sets).

Static electricity can build up on your body and can easily damage sensitive internal circuit elements when discharged. Static discharges too small to be felt can cause permanent damage. Devices such as calibration components and devices under test (DUTs), can also carry an electrostatic charge. To prevent damage to the test set, components, and devices:

- *always* wear a grounded wrist strap having a 1 M Ω resistor in series with it when handling components and devices or when making connections to the test set.
- *always* use a grounded, conductive table mat while making connections.
- *always* wear a heel strap when working in an area with a conductive floor. If you are uncertain about the conductivity of your floor, wear a heel strap.
- *always* ground yourself before you clean, inspect, or make a connection to a static-sensitive device or test port. You can, for example, grasp the grounded outer shell of the test port or cable connector briefly.
- *always* ground the center conductor of a test cable before making a connection to the analyzer test port or other static-sensitive device. This can be done as follows:
 1. Connect a short (from your calibration kit) to one end of the cable to short the center conductor to the outer conductor.
 2. While wearing a grounded wrist strap, grasp the outer shell of the cable connector.
 3. Connect the other end of the cable to the test port.
 4. Remove the short from the cable.

Refer to [Chapter 6](#), “Replaceable Parts,” for part numbers and instructions for ordering ESD protection devices.

Figure 3-1 ESD Protection Setup

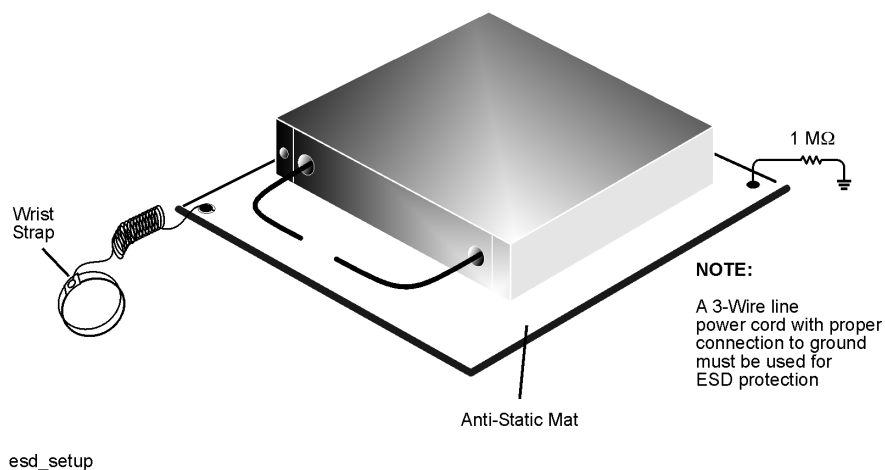

Visual Inspection

Visual inspection and, if necessary, cleaning should be done every time a connection is made. Metal particles from the connector threads may fall into the connector when it is disconnected. One connection made with a dirty or damaged connector can damage both connectors beyond repair.

In some cases, magnification is necessary to see damage to a connector; a magnifying device with a magnification of $\geq 10\times$ is recommended. However, not all defects that are visible only under magnification will affect the electrical performance of the connector. Use the following guidelines when evaluating the integrity of a connector.

Look for Obvious Defects and Damage First

Examine the connectors first for obvious defects and damage: badly worn plating on the connector interface, deformed threads, or bent, broken, or misaligned center conductors. Connector nuts should move smoothly and be free of burrs, loose metal particles, and rough spots.

What Causes Connector Wear?

Connector wear is caused by connecting and disconnecting the devices. The more use a connector gets, the faster it wears and degrades. The wear is greatly accelerated when connectors are not kept clean, or are connected incorrectly.

Connector wear eventually degrades performance of the device. Calibration devices should have a long life if their use is on the order of a few times per week. Replace devices with worn connectors.

The test port connectors on the network analyzer test set may have many connections each day, and are therefore more subject to wear. It is recommended that an adapter be used as a test port saver to minimize the wear on the test set's test port connectors.

Inspect the Mating Plane Surfaces

Flat contact between the connectors at all points on their mating plane surfaces is required for a good connection. See [Figure 2-1 on page 2-3](#). Look especially for deep scratches or dents, and for dirt and metal particles on the connector mating plane surfaces. Also look for signs of damage due to excessive or uneven wear or misalignment.

Light burnishing of the mating plane surfaces is normal, and is evident as light scratches or shallow circular marks distributed more or less uniformly over the mating plane surface. Other small defects and cosmetic imperfections are also normal. None of these affect electrical or mechanical performance.

If a connector shows deep scratches or dents, particles clinging to the mating plane surfaces, or uneven wear, clean and inspect it again. Devices with damaged connectors should be discarded. Determine the cause of damage before connecting a new, undamaged connector in the same configuration.

Inspect Female Connectors

Pay special attention to the contact fingers in the female center conductor. These can be bent or broken, and damage to them is not always easy to see. A connector with damaged contact fingers will not make good electrical contact and must be replaced.

NOTE This is particularly important when mating nonprecision to precision devices.

Cleaning Connectors

Clean connectors are essential for ensuring the integrity of RF and microwave coaxial connections.

1. Use Compressed Air or Nitrogen

WARNING Always use protective eyewear when using compressed air or nitrogen.

Use compressed air (or nitrogen) to loosen particles on the connector mating plane surfaces. Clean air cannot damage a connector or leave particles or residues behind.

You can use any source of clean, dry, low-pressure compressed air or nitrogen that has an effective oil-vapor filter and liquid condensation trap placed just before the outlet hose.

Ground the hose nozzle to prevent electrostatic discharge, and set the air pressure to less than 414 kPa (60 psi) to control the velocity of the air stream. High-velocity streams of compressed air can cause electrostatic effects when directed into a connector. These electrostatic effects can damage the device. Refer to [“Electrostatic Discharge” on page 3-2](#) for additional information.

2. Clean the Connector Threads

WARNING Keep isopropyl alcohol away from heat, sparks, and flame. Store in a tightly closed container. It is extremely flammable. In case of fire, use alcohol foam, dry chemical, or carbon dioxide; water may be ineffective.

Use isopropyl alcohol with adequate ventilation and avoid contact with eyes, skin, and clothing. It causes skin irritation, may cause eye damage, and is harmful if swallowed or inhaled. It may be harmful if absorbed through the skin. Wash thoroughly after handling.

In case of spill, soak up with sand or earth. Flush spill area with water.

Dispose of isopropyl alcohol in accordance with all applicable federal, state, and local environmental regulations.

Use a lint-free swab or cleaning cloth moistened with isopropyl alcohol to remove any dirt or stubborn contaminants on a connector that cannot be removed with compressed air or nitrogen. Refer to [Table 6-2 on page 6-4](#) for part numbers for isopropyl alcohol and cleaning swabs.

- a. Apply a small amount of isopropyl alcohol to a lint-free cleaning swab.
- b. Clean the connector threads.
- c. Let the alcohol evaporate, then blow the threads dry with a gentle stream of clean, low-pressure compressed air or nitrogen. Always completely dry a connector before you reassemble or use it.

3. Clean the Mating Plane Surfaces

- a. Apply a small amount of isopropyl alcohol to a lint-free cleaning swab.
- b. Clean the center and outer conductor mating plane surfaces. Refer to [Figure 2-1 on page 2-3](#). When cleaning a female connector, avoid snagging the swab on the center conductor contact fingers by using short strokes.
- c. Let the alcohol evaporate, then blow the connector dry with a gentle stream of clean, low-pressure compressed air or nitrogen. Always completely dry a connector before you reassemble or use it.

4. Reinspect

Inspect the connector again to make sure that no particles or residue are present.

Connections

Good connections require a skilled operator. *The most common cause of measurement error is bad connections.* The following procedures illustrate how to make good connections.

How to Make a Connection

Preliminary Connection

1. Ground yourself and all devices. Wear a grounded wrist strap and work on a grounded, conductive table mat. Refer to [“Electrostatic Discharge” on page 3-2](#) for ESD precautions.
2. Visually inspect the connectors. Refer to [“Visual Inspection” on page 3-3](#).
3. If necessary, clean the connectors. Refer to [“Cleaning Connectors” on page 3-4](#).
4. Carefully align the connectors. The male connector center pin must slip concentrically into the contact finger of the female connector.
5. Push the connectors straight together.

CAUTION Do *not* turn the device body. Only turn the connector nut. Damage to the center conductor can occur if the device body is twisted.

Connections

Do *not* twist or screw the connectors together. As the center conductors mate, there is usually a slight resistance.

- The preliminary connection is tight enough when the mating plane surfaces make uniform, light contact. Do not overtighten this connection.

A connection in which the outer conductors make gentle contact at all points on both mating surfaces is sufficient. Very light finger pressure is enough to accomplish this.

- Make sure the connectors are properly supported. Relieve any side pressure on the connection from long or heavy devices or cables.

Final Connection Using a Torque Wrench

- Use a torque wrench to make a final connection. [Table 3-1](#) provides information about the torque wrench recommended for use with these calibration kits. A torque wrench is included in the 85038A calibration kit but not in the 85038F/M calibration kits. Refer to [Chapter 6](#) for part number and ordering information.

Table 3-1 Torque Wrench Information

Connector Type	Torque Setting	Torque Tolerance
7-16	226 N-cm (20 in-lb)	± 22.6 N-cm (± 2.0 in-lb)

Using a torque wrench guarantees that the connection is not too tight, preventing possible connector damage. It also guarantees that all connections are equally tight each time.

- Prevent the rotation of anything other than the connector nut that you are tightening. It may be possible to do this by hand if one of the connectors is fixed (as on a test port). In all situations, however, it is recommended that you use an open-end wrench to keep the body of the device from turning. Refer to [Chapter 6](#) for part number and ordering information.
- Position both wrenches within 90 degrees of each other before applying force. See [Figure 3-2](#). Wrenches opposing each other (greater than 90 degrees apart) will cause a lifting action which can misalign and stress the connections of the devices involved. This is especially true when several devices are connected together.

Figure 3-2 Wrench Positions

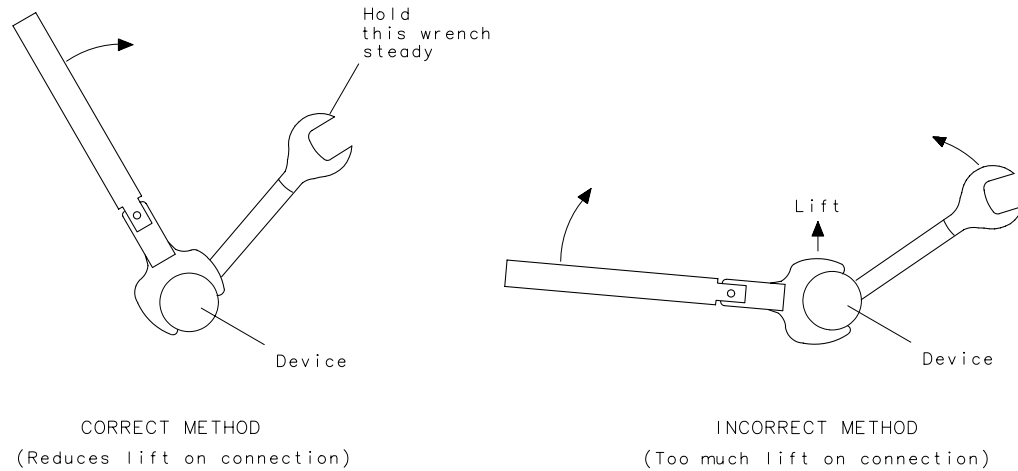

wj56f

4. Hold the torque wrench lightly, at the end of the handle only (beyond the groove). See [Figure 3-3](#).

Figure 3-3 Using the Torque Wrench

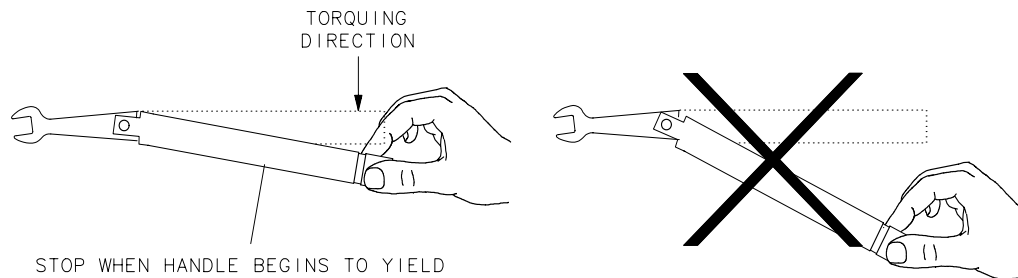

wj68d

5. Apply force perpendicular to the wrench handle. This applies torque to the connection through the wrench.

Do not hold the wrench so tightly that you push the handle straight down along its length rather than pivoting it, otherwise you apply an unknown amount of torque.

6. Tighten the connection just to the torque wrench break point. The wrench handle gives way at its internal pivot point. See [Figure 3-3](#). Do not tighten the connection further.

CAUTION You don't have to fully break the handle of the torque wrench to reach the specified torque; doing so can cause the handle to kick back and loosen the connection. Any give at all in the handle is sufficient torque.

Do not pivot the wrench handle on your thumb or other fingers, otherwise you apply an unknown amount of torque to the connection when the wrench reaches its break point.

Do not twist the head of the wrench relative to the outer conductor mating plane. If you do, you apply more than the recommended torque.

How to Separate a Connection

To avoid lateral (bending) force on the connector mating plane surfaces, always support the devices and connections.

CAUTION Do *not* turn the device body. Only turn the connector nut. Damage to the center conductor can occur if the device body is twisted.

1. Use an open-end wrench to prevent the device body from turning.
2. Use another open-end wrench to loosen the connector nut.
3. Complete the separation by hand, turning only the connector nut.
4. Pull the connectors straight apart without twisting, rocking, or bending either of the connectors.

Handling and Storage

- Install the protective end caps and store the calibration devices in the foam-lined storage case when not in use.
- Never store connectors loose in a box, or in a desk or bench drawer. This is the most common cause of connector damage during storage.
- Keep connectors clean.
- Do not touch mating plane surfaces. Natural skin oils and microscopic particles of dirt are easily transferred to a connector interface and are very difficult to remove.
- Do not set connectors contact-end down on a hard surface. The plating and the mating plane surfaces can be damaged if the interface comes in contact with any hard surface.

4 Performance Verification

Introduction

The performance of your calibration kit can only be verified by returning the kit to Agilent Technologies for recertification. The equipment required to verify the specifications of the devices in the kit has been specially manufactured and is not commercially available.

How Agilent Verifies the Devices in Your Kit

Agilent verifies the specifications of these devices as follows:

1. The residual microwave error terms of the test system are verified with precision airlines and shorts that are directly traced to the National Institute of Standards and Technology (NIST). The airline and short characteristics are developed from mechanical measurements. The mechanical measurements and material properties are carefully modeled to give very accurate electrical representation. The mechanical measurements are then traced to NIST through various plug and ring gages and other mechanical measurements.
2. Each calibration device is electrically tested on this system. For the initial (before sale) testing of the calibration devices, Agilent includes the test measurement uncertainty as a guardband to guarantee each device meets the published specification. For recertifications (after sale), no guardband is used and the measured data is compared directly with the specification to determine the pass or fail status. The measurement uncertainty for each device is, however, recorded in the calibration report that accompanies recertified kits.

These two steps establish a traceable link to NIST for Agilent to the extent allowed by the institute's calibration facility. The specifications data provided for the devices in your kit is traceable to NIST through Agilent Technologies.

Recertification

The following will be provided with a recertified kit:

- a new calibration sticker affixed to the case
- a certificate of calibration
- a calibration report for each device in the kit listing measured values, specifications, and uncertainties

NOTE A list of NIST traceable numbers may be purchased upon request to be included in the calibration report.

Agilent Technologies offers a *Standard* calibration for the recertification of your kit. For more information, contact Agilent Technologies. For contact information, see [Table 5-1 on page 5-3](#).

How Often to Recertify

The suggested initial interval for recertification is 12 months or sooner. The actual need for recertification depends on the use of the kit. After reviewing the results of the initial recertification, you may establish a different recertification interval that reflects the usage and wear of the kit.

NOTE The recertification interval should begin on the date the kit is *first used* after the recertification date.

Where to Send a Kit for Recertification

Contact Agilent Technologies for information on where to send your kit for recertification. For contact information, see [Table 5-1 on page 5-3](#).

When you return the kit, complete and attach a service tag. Refer to "[Returning a Kit or Device to Agilent](#)," on page 5-3 for details.

5 Troubleshooting

Troubleshooting Process

If you suspect a bad calibration, or if your network analyzer does not pass performance verification, follow the steps in [Figure 5-1](#).

Figure 5-1 Troubleshooting Flowchart

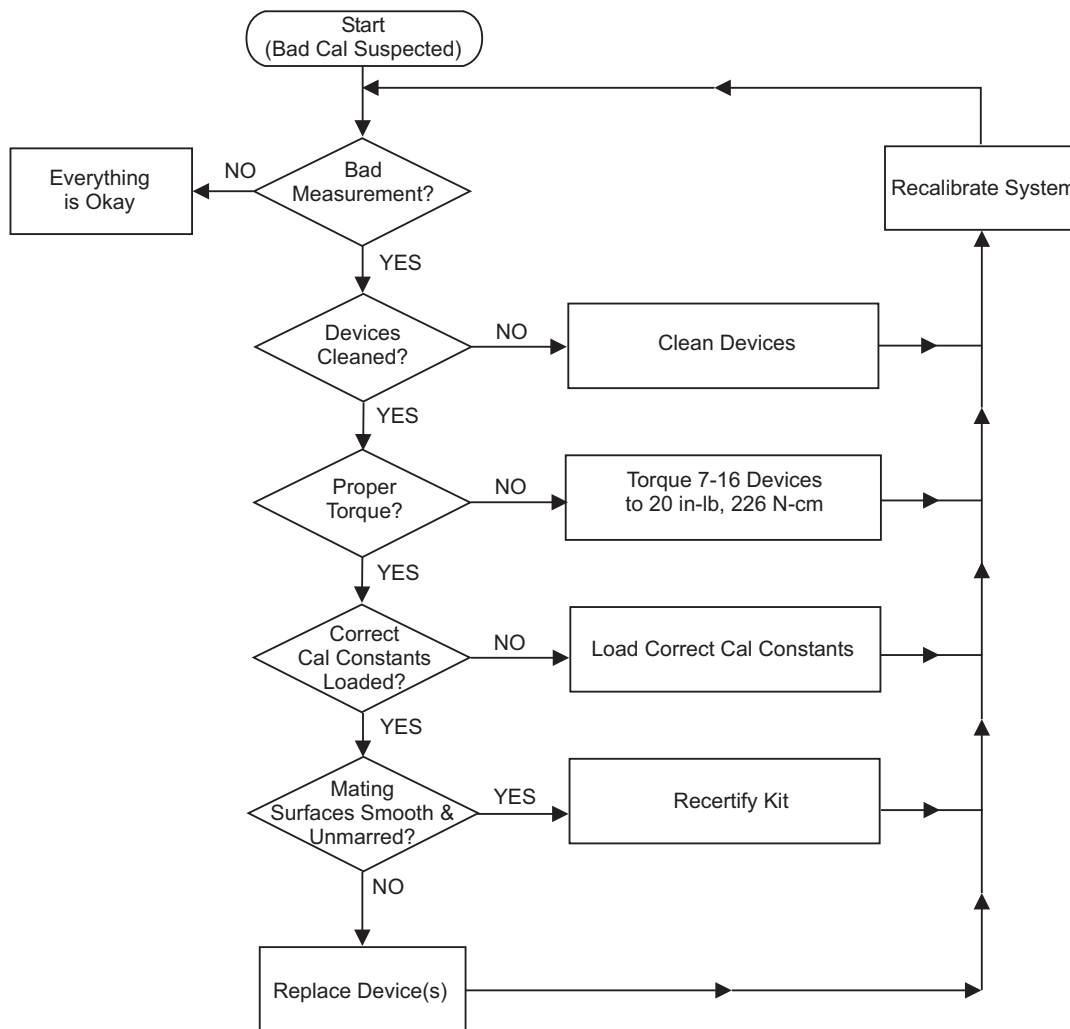

pn43m

Returning a Kit or Device to Agilent

If your kit or device requires service, contact Agilent Technologies for information on where to send it. For contact information, see [Table 5-1](#). Include a service tag (located near the end of this manual) on which you provide the following information:

- your company name and address
- a technical contact person within your company, and the person's complete phone number
- the model number and serial number of the kit
- the part number and serial number of each device
- the type of service required
- a *detailed* description of the problem and how the device was being used when the problem occurred (such as calibration or measurement)

Contacting Agilent

Table 5-1 Contacting Agilent

Online assistance: www.agilent.com/find/assist

United States <i>(tel)</i> 1 800 452 4844	Latin America <i>(tel)</i> (305) 269 7500 <i>(fax)</i> (305) 269 7599	Canada <i>(tel)</i> 1 877 894 4414 <i>(fax)</i> (905) 282-6495	Europe <i>(tel)</i> (+31) 20 547 2323 <i>(fax)</i> (+31) 20 547 2390
New Zealand <i>(tel)</i> 0 800 738 378 <i>(fax)</i> (+64) 4 495 8950	Japan <i>(tel)</i> (+81) 426 56 7832 <i>(fax)</i> (+81) 426 56 7840	Australia <i>(tel)</i> 1 800 629 485 <i>(fax)</i> (+61) 3 9210 5947	Singapore <i>(tel)</i> 1 800 375 8100 <i>(fax)</i> (65) 836 0252
Malaysia <i>(tel)</i> 1 800 828 848 <i>(fax)</i> 1 800 801 664	Philippines <i>(tel)</i> (632) 8426802 <i>(tel) (PLDT subscriber only):</i> 1 800 16510170 <i>(fax)</i> (632) 8426809 <i>(fax) (PLDT subscriber only):</i> 1 800 16510288	Thailand <i>(tel) outside Bangkok:</i> (088) 226 008 <i>(tel) within Bangkok:</i> (662) 661 3999 <i>(fax)</i> (66) 1 661 3714	Hong Kong <i>(tel)</i> 800 930 871 <i>(fax)</i> (852) 2506 9233
Taiwan <i>(tel)</i> 0800-047-866 <i>(fax)</i> (886) 2 25456723	People's Republic of China <i>(tel) (preferred):</i> 800-810-0189 <i>(tel) (alternate):</i> 10800-650-0021 <i>(fax)</i> 10800-650-0121	India <i>(tel)</i> 1-600-11-2929 <i>(fax)</i> 000-800-650-1101	

6 Replaceable Parts

Introduction

Table 6-1 lists the replacement part numbers for items included in the 85038A/F/M calibration kits and Figure 6-1 illustrates each of these items.

Table 6-2 on page 6-4 lists the replacement part numbers for items not included in the calibration kits that are either required or recommended for successful operation of the kits.

To order a listed part, note the description, the part number, and the quantity desired. Telephone or send your order to Agilent Technologies. For contact information, see Table 5-1 on page 5-3.

Figure 6-1 Replaceable Parts for the 85038A/F/M Calibration Kits

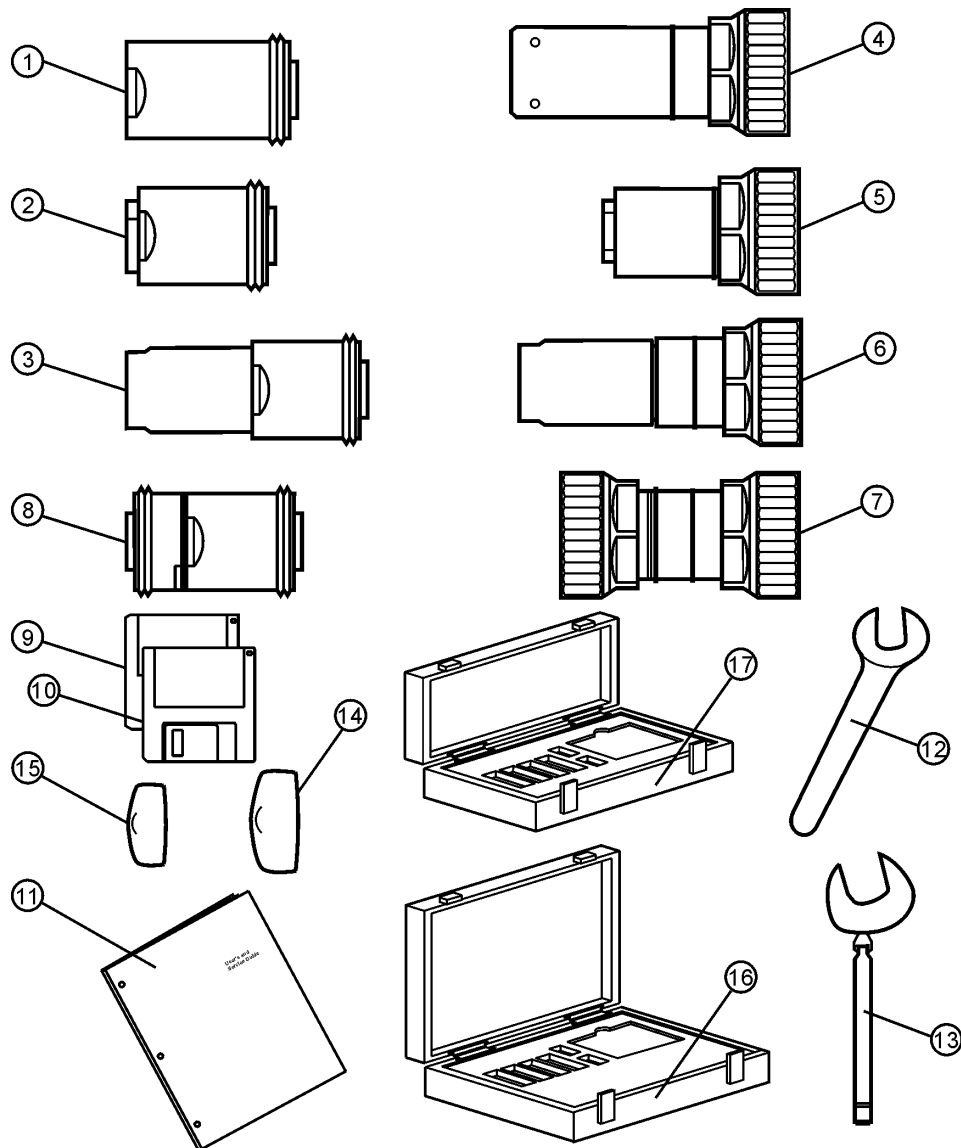

pn41m

Table 6-1 Replaceable Parts for the 85038A/F/M Calibration Kits

Item No.	Description	Part of 85038A	Part of 85038F	Part of 85038M	Qty per kit	Agilent Part Number
Calibration Devices (7-16)^a						
1	Female open	✓	✓		1	85038-80002
2	Female short	✓	✓		1	85038-80004
3	Female load	✓	✓		1	85038-80006
4	Male open	✓		✓	1	85038-80003
5	Male short	✓		✓	1	85038-80005
6	Male load	✓		✓	1	85038-80007
Adapters (7-16)^a						
7	Male to male			✓	1	11906-80015
8	Female to female		✓		1	11906-80016
Calibration Constants Disks						
9	For 8510, 872x family, and 8753	✓	✓	✓	1	85038-10001
10	For 871x family ^b	✓	✓	✓	1	85038-10002
Calibration Kit Manual						
11	User's and service guide	✓	✓	✓	1	85038-90010
Wrenches						
12	Open-end wrench	✓			1	8710-2174
13	Torque wrench	✓			1	8710-2175
Protective End Caps for Connectors						
14	For male devices	✓		✓	as required	1401-0418
15	For female devices	✓	✓		as required	1401-0417
Storage Cases						
16	Box (with foam inserts)	✓			1	85038-80010
17	Box (with foam inserts)		✓	✓	1	85038-80017

a. See "Clarifying the Sex of a Connector" on page 1-5.

b. This disk also contains calibration definitions for the PNA series.

Table 6-2 Replaceable Parts—Items Not Included in the Calibration Kits

Description	Qty	Agilent Part Number
Adapter Kits		
7-16 to 7-16 (includes the following three adapters:)	1	11906A
7-16-male to 7-16-male	1	11906-80015
7-16-female to 7-16-female	1	11906-80016
7-16-male to 7-16-female	1	11906-80017
7-16 to type-N (includes the following four adapters:)	1	11906B
7-16-male to type-N-male	1	11906-80007
7-16-female to type-N-female	1	11906-80008
7-16-male to type-N-female	1	11906-80009
7-16-female to type-N-male	1	11906-80010
7-16 to 7-mm (includes the following two adapters:)	1	11906C
7-16-male to 7-mm	1	11906-80012
7-16-female to 7-mm	1	11906-80013
7-16 to 3.5-mm (includes the following four adapters:)	1	11906D
7-16-male to 3.5-mm-male	1	11906-80002
7-16-female to 3.5-mm-male	1	11906-80005
7-16-male to 3.5-mm female	1	11906-80004
7-16-female to 3.5-mm female	1	11906-80003
ESD Protection Devices		
Grounding wrist strap	1	9300-1367
5 ft grounding cord for wrist strap	1	9300-0980
2 ft by 4 ft conductive table mat with 15 ft grounding wire	1	9300-0797
ESD heel strap	1	9300-1308
Connector Cleaning Supplies		
Isopropyl alcohol	30 ml	8500-5344
Foam-tipped cleaning swabs	100	9301-1243

A Standard Definitions

Version Changes

Class assignments and standard definitions may change as more accurate model and calibration methods are developed. The disk shipped with the kit will contain the most recent version.

Standard Class Assignments

Class assignment organizes calibration standards into a format compatible with the error models used in the measurement calibration. A class or group of classes corresponds to the systematic errors to be removed from the measured network analyzer response. [Table A-1](#) and [Table A-2](#) list the classes of the devices in these calibration kits. This information resides on the calibration definitions disks included in these kits.

Table A-1 Standard Class Assignments for 8753 and 872x Families

Calibration Kit Label: 7-16 or 85038								
Class	A	B	C	D	E	F	G	Standard Class Label
S ₁₁ A	2							Opens
S ₁₁ B	1							Shorts
S ₁₁ C	3							Load
S ₂₂ A	2							Opens
S ₂₂ B	1							Shorts
S ₂₂ C	3							Load
Forward transmission	4							Thru
Reverse transmission	4							Thru
Forward match	4							Thru
Reverse match	4							Thru
Response	1	2	4					Response
Response and isolation	1	2	4					Response & Isol'n

Table A-2 Standard Class Assignments for PNA Series

Calibration Kit Label: 7-16 or 85038								
Class	A	B	C	D	E	F	G	Standard Class Label
S ₁₁ A	2							Opens
S ₁₁ B	1							Shorts
S ₁₁ C	3							Loads
S ₂₂ A	2							Opens
S ₂₂ B	1							Shorts
S ₂₂ C	3							Loads
S ₂₁ T	4							Thru
S ₁₂ T	4							Thru

Blank Form

The standard class assignments listed in [Table A-1](#) and [Table A-2](#) may be changed to meet your specific requirements. [Table A-3](#) and [Table A-4](#) are provided to record the modified standard class assignments.

Table A-3 Standard Class Assignments Blank Form for 8753 and 872x Families

Calibration Kit Label: 7-16 or 85038								
Class	A	B	C	D	E	F	G	Standard Class Label
S ₁₁ A								
S ₁₁ B								
S ₁₁ C								
S ₂₂ A								
S ₂₂ B								
S ₂₂ C								
Forward transmission								
Reverse transmission								
Forward match								
Reverse match								
Response								
Response and isolation								

Table A-4 Standard Class Assignments Blank Form for PNA Series

Calibration Kit Label: 7-16 or 85038								
Class	A	B	C	D	E	F	G	Standard Class Label
S ₁₁ A								
S ₁₁ B								
S ₁₁ C								
S ₂₂ A								
S ₂₂ B								
S ₂₂ C								
S ₂₁ T								
S ₁₂ T								

Nominal Standard Definitions

Standard definitions provide the definitions needed to mathematically model the electrical characteristics (delay, attenuation, and impedance) of each calibration standard. The nominal values of these definitions are theoretically derived from the physical dimensions and material of each calibration standard, or from actual measured response. These values are used to determine the measurement uncertainties of the network analyzer. The standard definitions in [Table A-5](#) lists typical calibration kit parameters used to specify the mathematical model of each device. [Table A-6](#) lists the standard definitions for the adapters recommended for use with these kits. The information in these tables must be loaded into the network analyzer to perform valid calibrations. Refer to your network analyzer user’s guide for instructions on loading calibration definitions.

NOTE The values in the standard definitions table are valid *only* over the specified operating temperature range.

Setting the System Impedance

These kits contain only 50 ohm devices. Ensure the system impedance (Z_0) is set to 50 ohms. Refer to your network analyzer’s user’s guide for instructions on setting system impedance.

Table A-5 Standard Definitions for PNA, 8753, 872x and 871x^a Families

System $Z_0^b = 50 \Omega$														Calibration Kit Label: 7-16 or 85038													
Standard ^c		$C0 \times 10^{-15} \text{ F}$	$C1 \times 10^{-27} \text{ F/Hz}$	$C2 \times 10^{-36} \text{ F/Hz}^2$	$C3 \times 10^{-45} \text{ F/Hz}^3$	Fixed, Sliding or Offset ^d	Offset			Frequency in GHz		Coax or Waveguide	Standard Label														
Number	Type						Delay in ps	Z_0 in Ω	Loss ^e in G Ω /s	Min ^f	Max																
1	Short						66.734	50	0.63	0.0	999.0	Coax	Short														
2	Open	32.0	100.0	-50.0	100.0		66.734	50	0.63	0.0	999.0	Coax	Open														
3	Load					Fixed	0.0	50	0.0	0.0	999.0	Coax	Broad-band ^g														
4	Delay/thru						0.0	50	0.0	0.0	999.0	Coax	Thru ^h														
5																											
6																											
7																											
8																											

- a. The 871x family of network analyzers does not use standard numbers. However, the values in this table are used to define the 7-16 calibration kit for an 871x analyzer.
- b. Ensure system Z_0 of network analyzer is set to 50 ohms.
- c. Open, short, load, delay/thru, or arbitrary impedance.
- d. Load or arbitrary impedance only.
- e. Skin loss factor; normalize at 1 GHz.
- f. For waveguide, minimum frequency is the same as F_{CO} .
- g. Fixed loads. (Refer to [Table 6-1 on page 6-3](#) for part numbers.)
- h. Test ports connected directly.

Table A-6 Standard Definitions for Adapters

System $Z_0^a = 50 \Omega$								
Standard ^b		Offset			Frequency in GHz		Coax or Waveguide	Standard Label
Number	Type	Delay in ps	Z_0 in Ω	Loss ^c in G Ω /s	Min ^d	Max		
1	Delay/thru	236.871	50	0.63	0.0	999.0	Coax	APC-7 ^e
2	Delay/thru	262.451	50	0.63	0.0	999.0	Coax	Type-N ^f
3	Delay/thru	165.961	50	0.63	0.0	999.0	Coax	In-Series ^g

- a. Ensure system Z_0 of network analyzer is set to 50 ohms.
- b. Open, short, load, delay/thru, or arbitrary impedance.
- c. Skin loss factor; normalize at 1 GHz.
- d. For waveguide, minimum frequency is the same as F_{CO} .
- e. Adapter kit 11906C. (Refer to [Table 6-2 on page 6-4](#) for part number.)
- f. Adapter kit 11906B. (Refer to [Table 6-2 on page 6-4](#) for part number.)
- g. Adapter kit 11906A. (Refer to [Table 6-2 on page 6-4](#) for part number.)

Blank Forms

The standard definitions listed in [Table A-5](#) and [Table A-6](#) may be changed to meet your specific requirements. [Table A-7](#) and [Table A-8](#) are provided to record the modified standard definitions.

Table A-7 Standard Definitions Blank Form for PNA, 8753, 872x and 871x^a Families

System $Z_0^b = 50 \Omega$		Calibration Kit Label: 7-16 or 85038											
Standard ^c		$C0 \times 10^{-15} \text{ F}$	$C1 \times 10^{-27} \text{ F/Hz}$	$C2 \times 10^{-36} \text{ F/Hz}^2$	$C3 \times 10^{-45} \text{ F/Hz}^3$	Fixed, Sliding or Offset ^d	Offset			Frequency in GHz		Coax or Waveguide	Standard Label
Number	Type						Delay in ps	Z_0 in Ω	Loss ^e in G Ω /s	Min ^f	Max		
1													
2													
3													
4													
5													
6													
7													
8													

- a. The 871x family of network analyzers does not use standard numbers. However, the values in this table can be used to define the 7-16 calibration kit for an 871x analyzer.
- b. Ensure system Z_0 of network analyzer is set to 50 ohms.
- c. Open, short, load, delay/thru, or arbitrary impedance.
- d. Load or arbitrary impedance only.
- e. Skin loss factor; normalize at 1 GHz.
- f. For waveguide, minimum frequency is the same as F_{CO} .

Table A-8 Standard Definitions Blank Form for Adapters

System $Z_0^a = 50 \Omega$								
Standard ^b		Offset			Frequency in GHz		Coax or Waveguide	Standard Label
Number	Type	Delay in ps	Z_0 in Ω	Loss ^c in G Ω /s	Min ^d	Max		
1	Delay/thru							
2	Delay/thru							
3	Delay/thru							

- a. Ensure system Z_0 of network analyzer is set to 50 ohms.
- b. Open, short, load, delay/thru, or arbitrary impedance.
- c. Skin loss factor; normalize at 1 GHz.
- d. For waveguide, minimum frequency is the same as F_{CO} .

Index

A

- adapter kits
 - part numbers, 6-4
- adapters
 - part numbers, 6-3
- Agilent Technologies
 - contacting, 5-3
- agreements
 - customer assistance, ii
 - maintenance, ii
- alcohol
 - isopropyl
 - as cleaning solvent, 3-5
 - part number, 6-4
 - precautions for use of, 3-4
- altitude
 - specifications, 2-2
- assistance
 - contacting agilent, 5-3
 - customer, ii
 - who to contact, ii

B

- blank form
 - standard class assignments, A-3
- box
 - part number, 6-3

C

- cal kit
 - performance
 - verifying, 4-2
- calibration
 - bad, 5-2
 - certificate of, 4-3
 - constants, 1-2
 - permanently stored, 1-3
 - MIL-STD 45662, 4-3
 - report, 4-3
 - temperature, 2-2
- calibration constants
 - disk, 6-3
 - entering, 1-2
 - permanently stored, 1-2
- calibration definitions, 1-2
- calibration kit
 - contents, 1-2, 6-2
 - drawing of, 6-2
 - overview, 1-2
 - performance
 - how Agilent verifies, 4-2
 - verifying, 4-2
- calibration report, 4-3
- case
 - part number, 6-3
- certificate of calibration, 4-3

- certification
 - of device specifications, 2-4
- characteristics
 - mechanical, 2-3
- class assignments
 - blank form, A-3
 - standard, A-2
- cleaning connectors, 3-4
- cleaning supplies, 1-3
 - part number, 6-4
- cleaning swabs, 3-5
 - part number, 6-4
- compressed air
 - for cleaning, 3-4
- connections, 3-2, 3-5
 - ESD protection, 3-5
 - final, 3-6
 - preliminary, 3-5
 - separating, 3-8
 - using torque wrench, 3-6
- connector
 - cleaning, 3-4
 - damage, 3-3
 - defects, 3-3
 - female, 3-4
 - mating plane surfaces, 3-5
 - cleaning, 3-5
 - sex, 1-5
 - clarifying, 1-5
 - threads
 - cleaning, 3-4
 - inspecting, 3-3
 - visual inspection, 3-3
 - wear, 3-3
 - affect on electrical performance, 3-3
- constants
 - calibration, 1-2
 - entering, 1-2
 - permanently stored, 1-2
 - contacting Agilent Technologies, 5-3
- contents
 - calibration kit, 6-2
 - drawing of, 6-2
 - incomplete
 - what to do, 1-3

D

- damage
 - device, 3-3
 - inspecting for, 3-3
 - to connectors, 3-3
 - what to do, 1-3
- damaged connectors, 3-3
- data
 - recertification, 4-3

- defective connectors, 3-3
- defects
 - connector, 3-3
- definitions
 - standard, A-4
- deviation from nominal phase, 2-4
- device
 - connecting, 3-5
 - damage, 3-3
 - disconnecting, 3-8
 - handling, 3-8
 - maintenance, 1-5
 - performance
 - verifying, 4-2
 - specifications, 2-4
 - certification of, 2-4
 - traceability, 4-2, 4-3
 - storage, 3-8
 - temperature, 2-2
 - visual inspection, 3-3
- disconnections, 3-8
- disk
 - calibration constants, 6-3
- documentation warranty, ii

E

- electrical specifications, 2-4
- electrostatic discharge, 3-2
 - supplies
 - part numbers, 6-4
- end caps
 - part numbers, 6-3
- environmental
 - regulations, 3-4
 - requirements, 2-2
 - specifications, 2-2
- equipment required, 1-3
- ESD, 3-2
 - precautions, 3-2, 3-4
 - supplies
 - part numbers, 6-4

F

- female connectors, 3-4
 - inspection of, 3-4
- frequency
 - specifications, 2-4

G

- gage
 - connector, 1-3

H

- handling, 3-8
- humidity
 - specifications, 2-2

Index

I

impedance
 system, [A-4](#)
 setting, [A-4](#)
incoming inspection, [1-3](#)
inspection
 damage, [3-3](#)
 defects, [3-3](#)
 female connectors, [3-4](#)
 incoming, [1-3](#)
 mating plane surfaces, [3-3](#)
 visual, [3-3](#)
isopropyl alcohol
 as cleaning solvent, [3-5](#)
 part number, [6-4](#)
 precautions for use of, [3-4](#)

K

kit
 contents, [1-2](#), [6-2](#)
 drawing of, [6-2](#)
 overview, [1-2](#)

L

loads
 part numbers, [6-3](#)
 specifications, [2-4](#)

M

maintenance, [3-2](#)
 agreements, [ii](#)
 preventive, [1-5](#)
maintenance of devices, [1-5](#)
making connections, [3-5](#)
 ESD protection, [3-5](#)
 precautions, [3-5](#)
mating plane surfaces
 cleaning, [3-5](#)
 connector, [3-5](#)
 inspection of, [3-3](#)
mechanical characteristics, [2-3](#)
 affect on electrical performance,
 [2-3](#)
MIL-STD 45662
 calibration, [4-3](#)

N

National Institute of Standards
 and Technology (NIST), [2-4](#),
 [4-2](#)
NIST (National Institute of
 Standards and Technology),
 [2-4](#), [4-2](#)
nitrogen
 for cleaning, [3-4](#)

nominal standard definitions, [A-4](#)
numbers
 serial, [1-4](#)

O

open-end wrench, [3-8](#)
 part number, [6-3](#)
opens
 part numbers, [6-3](#)
 specifications, [2-4](#)
ordering
 parts, [6-2](#)

P

part numbers, [6-2](#)
 of items in kit, [6-3](#)
 of items not in kit, [6-4](#)
parts
 not included in kit, [6-2](#)
 ordering, [6-2](#)
 replaceable, [6-2](#)
performance verification
 fail, [5-2](#)
permanently stored calibration
 definitions, [1-3](#)
pin depth, [2-3](#)
 protrusion, [2-3](#)
 recession, [2-3](#)
 typical values, [2-3](#)
preventive maintenance, [1-5](#)
protective end caps
 part numbers, [6-3](#)
protrusion
 pin depth, [2-3](#)

R

recertification
 how to order, [4-3](#)
 interval, [4-3](#)
 what's included, [4-3](#)
 where it's done, [4-3](#)
recession
 pin depth, [2-3](#)
regulations
 environmental, [3-4](#)
replaceable parts, [6-2](#)
 drawing of, [6-2](#)
requirements
 environmental, [2-2](#)
return
 kit or device to Agilent, [5-3](#)
return loss
 specifications, [2-4](#)

S

separating connections, [3-8](#)

serial numbers, [1-4](#)
 devices, [1-4](#)
 recording, [1-4](#)
service, [5-3](#)
 tag, [1-3](#), [4-3](#), [5-3](#)
shorts
 part numbers, [6-3](#)
 specifications, [2-4](#)
specifications, [2-2](#)
 altitude
 operating, [2-2](#)
 storage, [2-2](#)
 certification of, [2-4](#)
 deviation from nominal phase,
 [2-4](#)
 device, [2-4](#)
 electrical, [2-4](#)
 environmental, [2-2](#)
 frequency, [2-4](#)
 humidity, [2-2](#)
 return loss, [2-4](#)
 temperature, [2-2](#)
 torque wrench, [3-6](#)
 traceability, [4-2](#), [4-3](#)
standard class assignments, [A-2](#)
 blank form, [A-3](#)
standard definitions, [A-4](#)
 nominal, [A-4](#)
standards
 international, [2-4](#), [4-2](#)
 National Institute of Standards
 and Technology (NIST), [2-4](#),
 [4-2](#)
static discharge, [3-2](#)
storage, [3-8](#)
 altitude, [2-2](#)
 temperature, [2-2](#)
storage case
 part number, [6-3](#)
supplies
 cleaning, [1-3](#)
 part number, [6-4](#)
swabs
 cleaning, [3-5](#)
system impedance, [A-4](#)

T

tag
 service, [1-3](#), [4-3](#), [5-3](#)
temperature
 affect on electrical performance,
 [2-2](#)
 calibration, [2-2](#)
 cautions about, [2-2](#)
 changes in, [2-2](#)
 device, [2-2](#)
 error-corrected, [2-2](#)

Index

measurement, 2-2
specifications, 2-2
 operating, 2-2
 storage, 2-2
verification and measurement,
 2-2
test data, 4-3
threads
 connector
 cleaning, 3-4
 inspecting, 3-4
torque wrench, 1-3
 part number, 6-3
 specifications, 3-6
traceability
 of device specifications, 4-2, 4-3
troubleshooting, 5-2

U

user's and service guide
 part number, 6-3

V

verification
 temperature, 2-2
visual inspection, 3-3

W

warranty, documentation, ii
wear
 connector, 3-3
 affect on electrical
 performance, 3-3
wrench
 open-end, 1-3, 3-7, 3-8
 part number, 6-3
 proper positioning of, 3-7
 torque, 1-3, 3-6, 3-7
 part number, 6-3
 precautions for use of, 3-7
 proper use of, 3-7